

ProComSol, Ltd

Process Communications Solutions

Advanced, low cost, high quality communication solutions for HART instrumentation

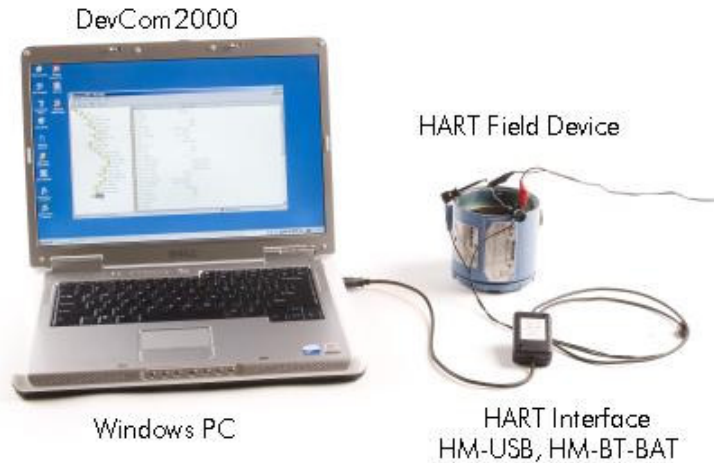

ProComSol, Ltd (Process Communications Solutions) was founded in 2005 dedicated to providing products for users of HART technology. We established our reputation with reliable USB HART modems certified by the HART Communication Foundation. The HM-USB HART Modem is the lowest cost certified USB HART Modem available.

As for technical innovations, our Bluetooth HART modems first appeared on the market in 2005. This makes us the first to offer wireless capabilities for HART users.

Our DevCom2000 HART Communicator software products have established themselves as the only real alternative to expensive communicators. DevCom2000 was originally released in 2006 as the first product to use the HART Communication Foundation's SDC-625 technology. Constant and steady improvements over the years have made DevCom2000 reliable, convenient, and feature rich.

ProComSol has always been a member of the HART Communication Foundation. We are committed to improving the HART protocol and offering high quality, reliable, and innovative products using this amazing technology. If you do not see products or features that you need, please contact us. We promise to work hard to meet your needs.

Thank you for your interest in our products,
ProComSol, Ltd

Table of Contents

DevCom2000, Smart Device Communication Software
 Brochure 3
 Datasheet 4

DevCom2000 PDA, Smart Device Communication Software PDA
 Brochure 5
 Datasheet 6

COM-PDA, Smart Communicator PDA
 Brochure 7
 Datasheet 8

COM-PPC, Smart Communicator PC
 Brochure 9
 Datasheet 10

DD-LIB-1YR, DD Library Subscription, 1 Year
 Brochure 11

HM-USB, HART Modem, USB
 Brochure 12
 Datasheet 13

HM-USB-ISO, HART Modem, USB, Isolated
 Brochure 14
 Datasheet 15

HM-BT-BAT-ER, HART Modem, Bluetooth
 Brochure 16
 Datasheet 17

HM-BT-VIN, HART Modem, Bluetooth, Ex
 Brochure 18
 Datasheet 19

BR2-KIT, Bracket, 2 Inch Pipe 20

Cabling Options 21

BT-ADAPTER, Bluetooth Class 1
 Brochure 22
 Datasheet 23

R-LOOP, Loop Resistor, 250 ohm 24

Price List 25

Quality, Warranty 26

Ordering Information 26

DevCom2000

Smart Device Communicator

Description:

- Perform complete HART device configurations using your PC or Laptop
- Uses the registered DD files from the HART Communication Foundation
- Complete access to all features of the device DD including Methods
- Monitor PV, Multi-variables, and Device Status
- View and edit device Variables
- The most affordable DD based HART communication solution available

Feature Highlights:

- Windows Explorer menu layout
- Device menu structure easy to navigate
- Get to the information you want quickly
- Communication and Event Logs
- Save configurations as text file or PDF file for documenting the device
- Write saved configurations to devices
- Complies with new Enhanced DDL standard (IEC 61804-3)
- Comes with all the latest registered DD's from the HART Foundation

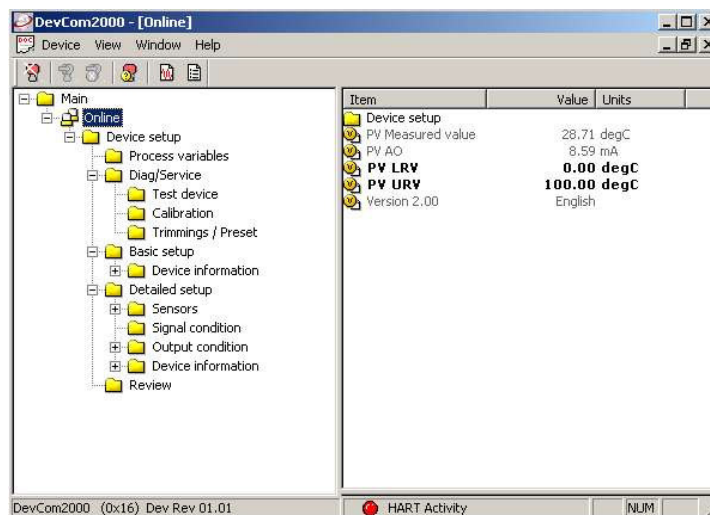

Sample Screen Shot

ProComSol, Ltd, (216) 221-1550, www.procomsol.com, sales@procomsol.com

DevCom2000

Smart Device Communicator

Specifications:

System Requirements (minimums)

Operating System	Windows NT, Windows 2000, Windows XP, Vista
Processor Speed	Pentium, 600 Mhz
Memory	256 MB
Hard Disk Space	500 MB
Monitor	256-color VGA
Communication Port	USB, RS232, or Bluetooth
HART Modem	ProComSol HM-USB, HM-BT-BAT, or equivalents

Device Descriptions (DD's)

DD Library	Included
Generic DD	Included
Current Library	HCF Release 2009 No. 1 (call for latest data)
Number of devices	900+ (call for latest data)
DD Updates	Quarterly updates for 1 year free Download updates with subscription service

Functions

- Monitor PV
- Monitor Multi-variables
- Monitor Device Status
- View and Edit Variables
- Save complete device configuration to text file and PDF file
- Write saved configurations to devices
- Execute Methods:
 - Trims
 - Calibrations
 - Loop Tests
 - Zero and Span
 - Etc.

DevCom2000 PDA

Smart Device Communicator

Description:

- Perform complete HART device configurations using your PDA
- Uses the registered DD files from the HART Communication Foundation
- Complete access to all features of the device DD including Methods
- Monitor PV, Multi-variables, and Device Status
- View and edit device Variables
- The most affordable DD based handheld HART communication solution available

Feature Highlights:

- Windows Explorer menu layout
- Device menu structure easy to navigate
- Get to the information you want quickly
- Save configurations for documenting the device
- Comes with all the latest registered DD's from the HART Foundation

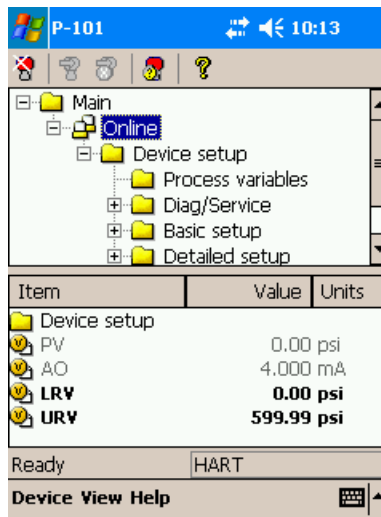

Sample Screen Shot

DevCom2000 PDA

Smart Device Communicator

Specifications:

System Requirements (minimums)

Operating System	Pocket PC 2003, Windows Mobile 5.0
Memory slot	SD Card
Memory	64 MB
Hard Disk Space	128 MB
Screen	256-color VGA
Communication Port	Bluetooth
HART Modem	ProComSol HM-BT-BAT, or equivalent

Device Descriptions (DD's)

DD Library	Included
Generic DD	Included
Current Library	HCF Release 2009 No. 1 (call for latest data)
Number of devices	900+ (call for latest data)
DD Updates	Quarterly updates for 1 year free Download updates with subscription service

Functions

- Monitor PV
- Monitor Multi-variables
- Monitor Device Status
- View and Edit Variables
- Save complete device configuration to text file
- Execute Methods:
 - Trims
 - Calibrations
 - Loop Tests
 - Zero and Span
 - Etc.

COM-PDA Smart Communicator PDA

Description:

Combines all the components needed for an affordable HART Hand-Held Communicator

Includes:

- Socket SoMo 650-E PDA with Bluetooth 2.0, 802.11b
- DevCom2000 PDA Smart Device Communicator Software
- SD Card containing the complete HART DD Library
- HM-BT-BAT-ER Bluetooth HART Modem
- Loop Resistor, 250 Ohm
- Rugged hard plastic case with carrying handle

All components installed, setup, and ready to go!



ProComSol, Ltd, (216) 221-1550, www.procomsol.com, sales@procomsol.com

COM-PDA

Smart Communicator PDA

Specifications:

Socket SoMo 650-E PDA

Operating System	Windows Mobile 5.0
Memory slot	SD Card
Memory RAM	128 MB
Memory ROM	256 MB
Screen	256-color VGA (240 x 320 pixels)
Communications	Bluetooth 2.0, 802.11b, IrDA

DevCom2000 PDA Smart Device Communicator Software

DD Library	Included
Generic DD	Included
Current Library	HCF Release 2009 No. 1 (call for latest data)
DD Updates	Quarterly updates for 1 year free

SD Card

Memory Size	2 GB
-------------	------

HM-BT-BAT-ER Bluetooth HART Modem Extended Range

Dimensions	2.00" x 2.75" x 0.80" (50mm x 70mm x 20mm)
Total Unit Weight	6 oz (170 g)
HART Specifications	HART 4, HART 5, HART 6, HART 7, HART Physical Layer Spec HCF_SPEC-54

Loop Resistor, 250 Ohm

Power Rating	1 Watt
--------------	--------

Carrying Case

Size	13-1/2" L x 10" W x 3-3/4" H
------	------------------------------

Note: For full specifications see individual datasheets

COM-PC

Smart Communicator PC



Description:

Combines all the components needed for our most popular PC based HART Communicator

Includes:

- DevCom2000 Smart Device Communicator Software
- HM-USB, HART Modem USB

Note: Computer not included. For kits including computers, see our COM-PC-TB52 or COM-PC-TB19

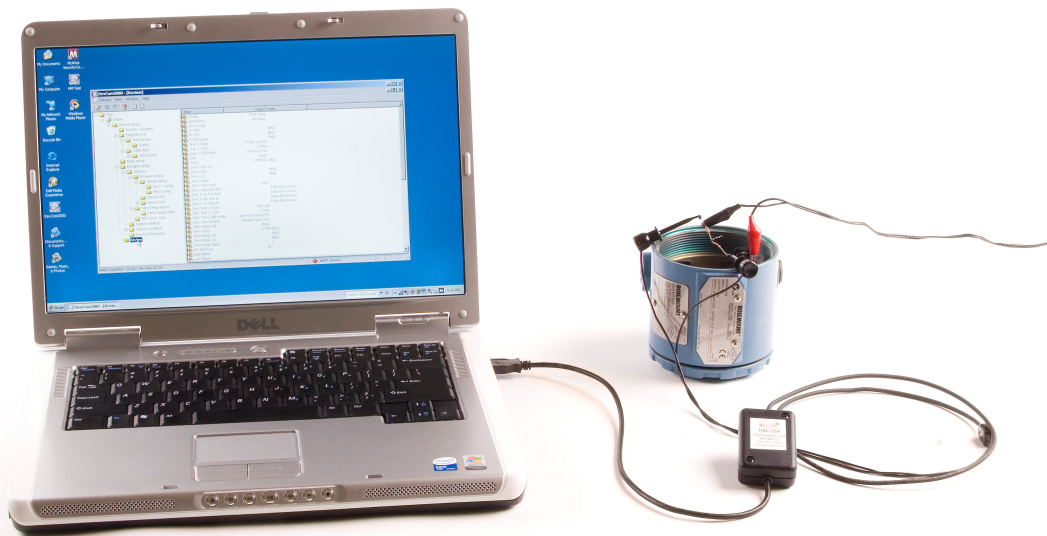

COM-PC

Smart Communicator PC



Specifications:

DevCom2000 Smart Device Communicator Software

DD Library	Included
Generic DD	Included
Current Library	HCF Release 2009 No. 1 (call for latest data)
DD Updates	Quarterly updates for 1 year, free
DD Specification	Enhanced DDL standard (IEC 61804-3)

HM-USB HART Modem USB

Dimensions	2.5" x 1.5" x 0.75" (64mm x 38mm x 19mm)
Total Unit Weight	3 oz (85 g)
HART Cable Length	4' (1.2 m)
HART Cable Connectors	Mini-Grabber
USB Cable Length	18" (0.5 m)
USB Cable Connector	USB Type A
HART Specifications	HART 4, HART 5, HART 6, HART 7, HART Physical Layer Spec HCF_SPEC-54
HART Foundation	Registration Number L2-06-1000-012
USB Specifications	USB 1.1, USB 2.0
Power	USB port provides power to unit
Current Draw	20mA

For full specifications see individual datasheets

Note: Computer not included. For kits including computers, see our COM-PC-TB52 or COM-PC-TB19

DD-LIB-1YR DD Library Subscription

Features:

- Keep your DD Library current with new Device Descriptions (DDs)
- Keeps your DD Library current with updated/revised DDs
- Access to DevCom2000 upgrades as well
- Easy to use web based updates
- 1 Year worth of updates (4 updates)

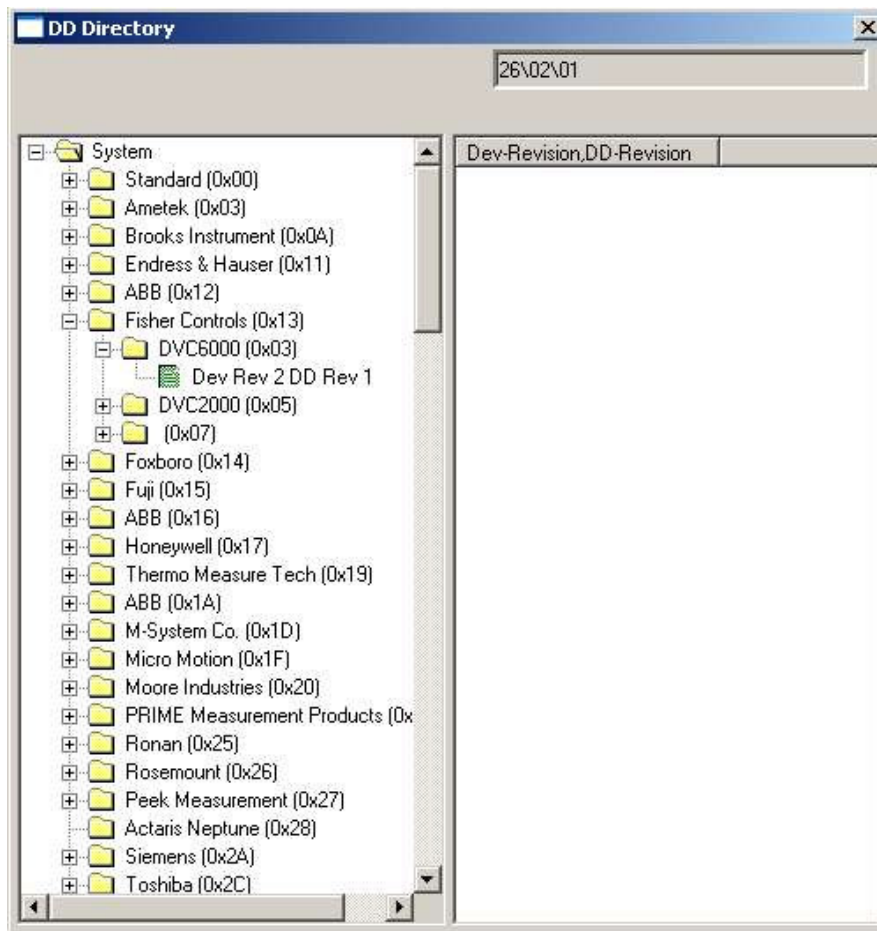

ProComSol, Ltd, (216) 221-1550, www.procomsol.com, sales@procomsol.com

HM-USB

HART Modem - USB

**Feature Highlights:**

- USB 1.1 and 2.0 compatible
- Integral standard USB type A connector
- Integral heavy duty HART Minigrabber connectors
- Certified to meet HART Physical Layer Spec HCF_SPEC-54
- Self powered, no external power supply or batteries needed
- 48" (1.2m) cable length
- Easy to install Virtual Serial Port for any Windows application
- Compact size 2.5" x 1.5" x 0.75" (64mm x 38mm x 19mm)
- Rugged ABS plastic enclosure
- Custom cable lengths available (CN-LENGTH)
- Banana plug option available (HM-USB-BP)
- HART Modem Test Program included
- HART Foundation Registered, Registration Number L2-06-1000-012
- Low cost



ProComSol, Ltd, (216) 221-1550, www.procomsol.com, sales@procomsol.com

HM-USB

HART Modem - USB



Specifications:

Enclosure

Material	High strength ABS Plastic
Dimensions	2.5" x 1.5" x 0.75" (64mm x 38mm x 19mm)
Total Unit Weight	3 oz (85 g)

Cables

HART Cable Length	4' (1.2 m)
HART Cable Connectors	Mini-Grabber
USB Cable Length	18" (0.5 m)
USB Cable Connector	USB Type A

HART

Interface	Capacitive coupling
Output	600 mVpp
Leakage	< 10 uA
Connections	Across loop resistor or HART field device
Specifications	HART 4, HART 5, HART 6, HART 7, HART Physical Layer Spec HCF_SPEC-54
HART Foundation	Registration Number L2-06-1000-012

USB

Specifications	USB 1.1, USB 2.0
Power	USB port provides power to unit
Current Draw	20mA

Environmental

Operating Temperature	0 degC to 50 degC (32 degF to 122 degF)
Storage Temperature	-40 degC to 85 degC (-40 degF to 185 degF)
Humidity	0% to 99% (non-condensing)

HM-USB-ISO

HART Modem – USB Isolated

Feature Highlights:

- 1500 Vdc Opto Isolation between HART and USB circuits
- USB 1.1 and 2.0 compatible
- Integral standard USB type A connector
- Integral heavy duty HART Minigrabber connectors
- Certified to meet HART Physical Layer Spec HCF_SPEC-54
- Self powered, no external power supply or batteries needed
- 48” (1.2m) cable length
- Easy to install Virtual Serial Port for any Windows application
- Compact size 2.75” x 2.0” x 0.8” (70mm x 51mm x 20mm)
- Rugged ABS plastic enclosure
- Custom cable lengths available (CN-LENGTH)
- Banana plug option available (HM-USB-ISO-BP)
- HART Modem Test Program included
- Low cost



ProComSol, Ltd, (216) 221-1550, www.procomsol.com, sales@procomsol.com

HM-USB-ISO

HART Modem – USB Isolated

Specifications:

Isolation

Isolation Voltage	1500 Vdc
Verification	Each unit 100% tested

Enclosure

Material	High strength ABS Plastic
Dimensions	2.75" x 2.0" x 0.8" (70mm x 51mm x 20mm)
Total Unit Weight	3 oz (85 g)

Cables

HART Cable Length	4' (1.2 m)
HART Cable Connectors	Mini-Grabber
USB Cable Length	18" (0.5 m)
USB Cable Connector	USB Type A

HART

Interface	Capacitive and transformer coupling
Output	600 mVpp
Leakage	< 10 uA
Connections	Across loop resistor or HART field device
Specifications	HART 4, HART 5, HART 6

USB

Specifications	USB 1.1, USB 2.0
Power	USB port provides power to unit
Current Draw	20mA

Environmental

Operating Temperature	0 degC to 50 degC (32 degF to 122 degF)
Storage Temperature	-40 degC to 85 degC (-40 degF to 185 degF)
Humidity	0% to 99% (non-condensing)

HM-BT-BAT-ER

HART Modem – Bluetooth Extended Range

Benefits:

- Access hard to reach instrumentation from the ground or your truck
- Improve plant personnel safety
- Easy instrument configuration using PDA's or PC's without bulky modules or wires
- Less clutter on desk or workbench

Feature Highlights:

- Bluetooth v2.0
- Reliable wireless communication up to 275 ft (83.8m)
- Internal antenna
- Rechargeable Li-Ion battery via mini-USB connector
- Integral heavy duty HART Minigrabber connectors
- Meets HART Physical Layer Spec HCF_SPEC-54
- High security 128 bit encryption
- Compact size 2.00" x 2.75" x 0.80" (50mm x 70mm x 20mm)
- Rugged ABS plastic enclosure
- Custom cable lengths available (CN-LENGTH)
- Banana plug option available (HM-BT-BAT-ER-BP)
- HART Modem Test Program included for PC and Pocket PC
- Integrated loop for hanging strap attachment



ProComSol, Ltd, (216) 221-1550, www.procomsol.com, sales@procomsol.com

HM-BT-BAT-ER

HART Modem – Bluetooth Extended Range

Specifications:

Enclosure

Material	High strength ABS Plastic
Dimensions	2.00" x 2.75" x 0.80" (50mm x 70mm x 20mm)
Total Unit Weight	6 oz (170 g)

Cables

HART Cable Length	4' (1.2 m)
HART Cable Connectors	Mini-Grabber

HART

Interface	Capacitive coupling
Output	600 mVpp
Leakage	< 10 uA
Connections	Across loop resistor or HART field device
Specifications	HART 4, HART 5, HART 6, HART 7, HART Physical Layer Spec HCF_SPEC-54

Bluetooth

Specifications	Bluetooth v2.0
Frequency	2.4 GHz
Class 1 Master Distance	275' (83.8m)
Class 2 Master Distance	25' (7.6m)

Battery

Type	Rechargeable Li-Ion
Life	19 hours continuous use

Environmental

Operating Temperature	0 degC to 50 degC (32 degF to 122 degF)
Storage Temperature	-40 degC to 85 degC (-40 degF to 185 degF)
Humidity	0% to 99% (non-condensing)

HM-BT-VIN

HART Modem – Bluetooth Voltage Input

Benefits:

- Access hard to reach instrumentation from the ground
- Easy instrument configuration using PDA's or PC's without bulky modules or wires
- Permanent in-field installation preserves explosion proof environment
- Explosion proof CSA, Class I Groups B, C and D. Class II Groups E, F and G.

Feature Highlights:

- Bluetooth v1.2
- Reliable wireless communication up to 100 ft (30m)
- Internal antenna
- Powered via 12Vdc to 36Vdc
- Bluetooth Activity and Power LEDs visible through glass cover
- Meets HART Physical Layer Spec HCF_SPEC-54
- High security 128 bit encryption
- Compact size 4.5" x 4.0" x 3.75" (115mm x 100mm x 95mm)
- Type 4X Enclosure.
- Conduit sizes ½ inch NPT (standard) and ¾ inch NPT (optional)
- HART Modem Test Program included for PC and Pocket PC PDA
- Optional Mounting Bracket available (BR2-KIT)



ProComSol, Ltd, (216) 221-1550, www.procomsol.com, sales@procomsol.com

HM-BT-VIN

HART Modem – Bluetooth Voltage Input

Specifications:

Enclosure

Material	Blue painted aluminum
Dimensions	4.5" x 4.0" x 3.75" (115mm x 100mm x 95mm)
Weight	1.3 lbs (0.54 kg)
Interface	Conduit sizes ½" NPT or ¾" NPT
Certifications	Explosion proof CSA, Class I Groups B, C, D. Class II Groups E, F, G Type 4X

HART

Interface	Capacitive coupling
Output	600 mVpp
Leakage	< 10 uA
Connections	Across loop resistor or HART field device
Specifications	HART 4, HART 5, HART 6, HART 7 HART Physical Layer Spec HCF_SPEC-54

Bluetooth

Specifications	Bluetooth v1.2
Frequency	2.4 GHz
Class 1 Master Distance	100' (30m)
Class 2 Master Distance	25' (7.6m)

Power Input

Voltage	12Vdc to 36Vdc
Power	600 mW

Environmental

Operating Temperature	-20 degC to 60 degC (-4 degF to 140 degF)
Storage Temperature	-40 degC to 85 degC (-40 degF to 185 degF)
Humidity	0% to 99% (non-condensing)

BR2-KIT
Bracket Kit
2 Inch Pipe

Feature Highlights:

- Designed for use with the HM-BT-VIN
- Mount the HM-BT-VIN directly to 2" piping
- 0.375" (9.5mm) holes for alternate mounting schemes
- Size 3.6" x 2.0" x 1.35" (91mm x 51mm x 34mm)
- 0.075" (2mm) thick stainless steel



Kit Contents

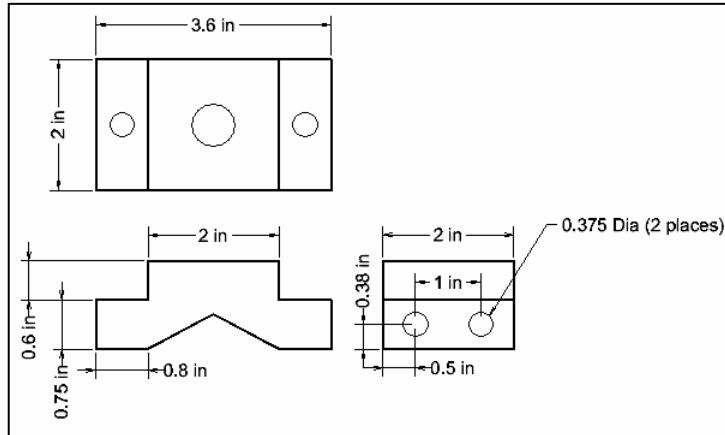

Bracket Dimensions

BT-ADAPTER

Bluetooth USB Adapter, Class 1

Benefits:

- Add Bluetooth capability to your PC
- Access hard to reach instrumentation from the ground or your truck
- Improve plant personnel safety
- Easy instrument configuration using PC's without bulky modules or wires
- Less clutter on desk or workbench

Feature Highlights:

- Bluetooth v2.0
- Compatible with Bluetooth v1.1 and v1.2
- Reliable wireless communication up to 330 ft (100m)
- Internal antenna
- USB connection
- Self powered via USB
- Compact size 2.95" x 2.20" x 0.43" (24mm x 56mm x 11mm)
- Rugged ABS plastic enclosure



BT-ADAPTER

Bluetooth USB Adapter, Class 1

Specifications:

Enclosure

Material	High strength ABS Plastic
Dimensions	0.95" x 2.2" x 0.43" (24mm x 56mm x 11mm)
Total Unit Weight	0.3 oz (8.5 g)

Operating Systems

Windows	2000, XP, Vista, Vista 64
---------	---------------------------

Bluetooth

Specifications	Bluetooth v2.0
Frequency	2.4 GHz
Range	330' (100m)

Environmental

Operating Temperature	0 degC to 50 degC (32 degF to 122 degF)
Storage Temperature	-40 degC to 85 degC (-40 degF to 185 degF)
Humidity	0% to 99% (non-condensing)

Cabling Options

We offer several cabling options to meet your application needs:

CN-LENGTH



Custom Cable Length Option

Change the standard 4 ft length to whatever length you need.

Order as:

CN-LENGTH – XX, Where XX is cable length in feet.

- BP



Banana Plug Option

Standard banana plugs allow the user to attach the tests connectors of their choice.

Order as:

HM-USB-BP – For USB-USB Modem

HM-BT-BAT-BP – For HM-BT-BAT Modem

CN-KIT-01



Banana Jack Connector Kit

Kit of four different connector types. Designed for use with the BP option modems.

Order as:

CN-KIT-01

R-LOOP
250 Ohm Resistor

Description:

250 ohm resistor provides necessary loop resistance for the HART signal.



Complete Systems

COM-PDA: Smart Communicator PDA	\$1999.99
COM-PC: Smart Communicator PC	\$999.98

Software

DevCom2000: Device Communicator Software	\$699.99
DevCom2000 PDA: Device Communicator Software PDA	\$999.99
DD-LIB-1YR: DD Library Subscription, 1 year	\$100.00

HART Modems

HM-USB: Standard USB Modem	\$299.99
HM-USB-BP: Banana Plug HART Cable Option	\$329.99
HM-USB-ISO: Isolated USB Modem	\$299.99
HM-USB-ISO-BP: Banana Plug HART Cable Option	\$329.99
HM-BT-BAT: Standard Bluetooth Modem	\$349.99
HM-BT-BAT-BP: Banana Plug HART Cable Option	\$379.99
HM-BT-VIN: Explosion Proof Bluetooth Modem	\$599.99
HM-BT-VIN-3/4: 3/4 Inch NPT Conduit Option	\$599.99
CN-LENGTH: Custom Cable Lengths	\$50.00

Accessories:

BT-ADAPTER: Bluetooth USB Adapter, Class 1	\$50.00
CN-KIT-01: Connector kit for –BP option units	\$50.00
BR2-KIT: Bracket Kit, 2 Inch Pipe	\$30.00
R-LOOP: 250 Ohm Loop Resistor	\$5.00

All prices in US Dollars

Quality

Our quality system has been registered to ISO 9001:2008. Initial registration in 2006.

Warranty

All Modems and Accessories are warranted to be free from defects for 1 year. All software media is warranted to be free from defects for 3 months.

Ordering

American Express, Visa, MasterCard, and Discover Accepted
Credit via Net 30 account also available for qualified customers
Order online, fax, or call direct

ProComSol, Ltd*Process Communications Solutions*

13000 Athens Ave, Suite 104G
Lakewood, OH 44107 USA

Phone: 216.221.1550

Fax: 216.221.1554

Email: sales@procomsol.comWeb: www.procomsol.com

Toll Free: 877.221.1551